

Pumping Trap: **New Product** Type GL81

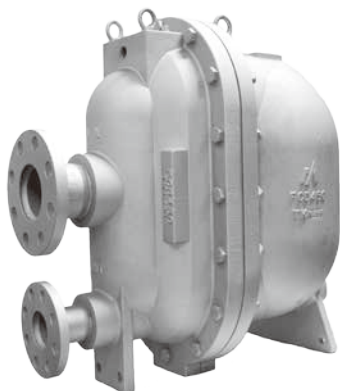

1. Pumping trap for the recovery of large condensate amounts.
2. As there is no electricity needed to return the condensate, the pumping trap can be used in hazardous areas.
3. The pumping trap will work with a low filling head of only 150 mm.
4. Air or saturated steam can be used as motive medium.
5. The internal parts are manufactured of high quality stainless steel.

Applications

- Condensate return from low pressure installations
- Condensate return to places located higher than the condensate vessel
- Condensate return from vacuum system

Pressure & Temperature

Model	Max. Allowable Pressure PMA		Max. Allowable Temperature TMA		Max. Operating Pressure PMO		Max. Operating Temperature TMO	
	MPa	psig	°C	°F	MPa	psig	°C	°F
GL81E	1,6	232	220	428	1,05	152	185	365
GL81	1,6	232	250	482	1,05	152	185	365

Connection & Body material

Model	Connection				Body material
	Inlet Condensate	Outlet Condensate	Inlet Motive Medium	Venting Outlet	
GL81E	Flanged PN16, ASME 150lb		Screwed Rc		Ductile Cast Iron FCD450 comparable with EN-GJS-450-10 (EN-JS1040)
	DN80 (3")	DN50 (2")	½"	1"	
GL81	Flanged JIS16KFF, ASME 150lb		Screwed Rc		
	DN80 (3")	DN50 (2")	½"	1"	

Flow Capacity Charts

Model: GL81E
Motive medium: Saturated Steam

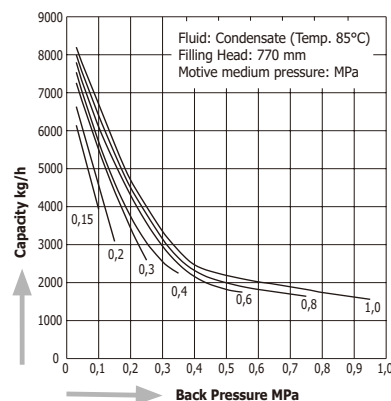

Model: GL81
Motive medium: Saturated Steam

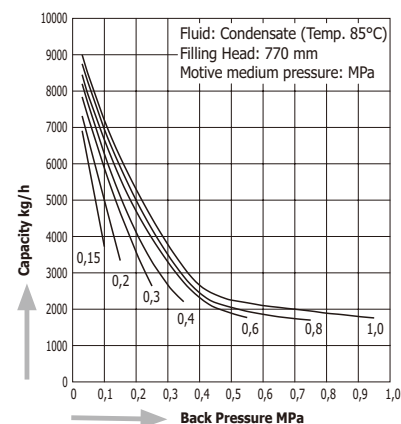

Spare Parts

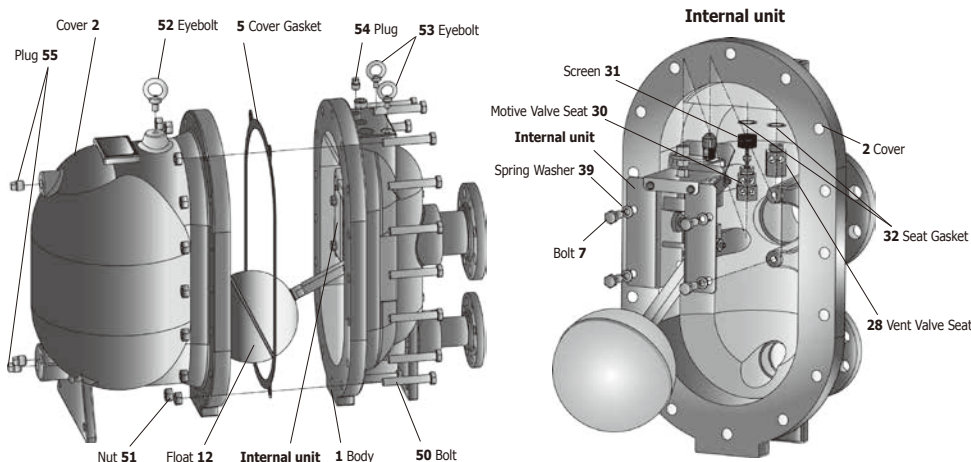

For more technical details of the new product, please, visit our Homepage www.miyawaki.net and download the English catalogue.

Issued: February 2019



MIYAWAKI Inc.
2-1-30, Tagawakita, Yodogawa-ku, Osaka 532-0021
JAPAN
Tel.: + 81 - 6 - 6302 - 5549
Fax: + 81 - 6 - 6305 - 7155
E-Mail: export@miyawaki-inc.co.jp
Website: www.miyawaki.net



MIYAWAKI GmbH
Birnbaumsmühle 65, 15234 Frankfurt (Oder)
GERMANY
Tel.: + 49 - 335 - 4007 0097
Fax: + 49 - 335 - 4000 122
E-Mail: info@miyawaki.de
Website: www.miyawaki.net